



ESLR9C/SPH - Silverlink 600 Electric Free-standing Oven Range - Castors at Rear - 6 Plates - W 900 mm - 13.0 kW [1-Phase]

This powerful six-plate electric range with a twin fan-assisted oven has the ability to cook large volumes of quality food, making it the ultimate solution for pubs, cafés, care homes and community centres on a single phase supply.

- ✔ Six hotplates and twin fan assisted oven for uniformed heat and consistent cooking
- ✔ Automatic power reduction, if pan boils dry or is removed - prolonging hotplate life
- ✔ Six-position control knob for each plate
- ✔ Large capacity oven for increased productivity
- ✔ Fully pressed and sealed hob tops ensure that the unit is both easy to clean and maintain
- ✔ Double insulated doors, side and back panels providing safer operation, greater efficiency, and economy

Specifications

Summary

Range Name	Silverlink 600
Power Type	Electric
Unit Type	Free-standing
Available in UK Only	No
UK Warranty	2 Years Parts and Labour Warranty
Export Warranty	Contact your local dealer
GTIN Code	5056105116424

Power and Performance

Total Power kW	13.0
Temperature Range °C	50 - 250
IP Rating	IP34
Temperature Control	Mechanical
Rating per Hob kW	6 x 1.5
Oven Rating kW	4.0

Key Specifications

Number of Shelves included	2
Number of Shelf Positions	4
Number of Hobs	6
Shape of Hob	Round

Weights and Dimensions

Unit Height (External) mm	932
Unit Width (External) mm	900
Unit Depth (External) mm	670
Height (Internal) mm	428
Width (Internal) mm	725
Depth (Internal) mm	342
Shelf Dimensions Width mm	700
Shelf Dimensions Depth mm	342
Hob Dimensions mm	W900 x D600
Net Weight Kg	95

Supply Connections

Requires Installation	Yes
Requires Electrical Supply	Yes
UK 3 Pin Plug	No
Requires Hardwiring	Yes
Electrical Supply Rating Watts	13,000
Single Phase Amps	56.5 [1 supp.]; 30.4/26.1 [2 supp.]
Single Phase Voltage	230

Shipping

Packed Weight Kg	110
Packed Height cm	110
Packed Width cm	100
Packed Depth cm	81

Available Accessories

SLR9/SB

SPLASHBACK SLR9/FL

Technical Picture

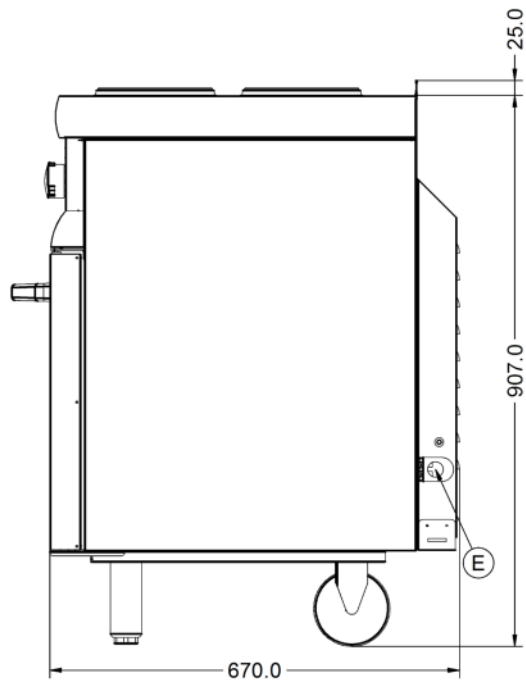
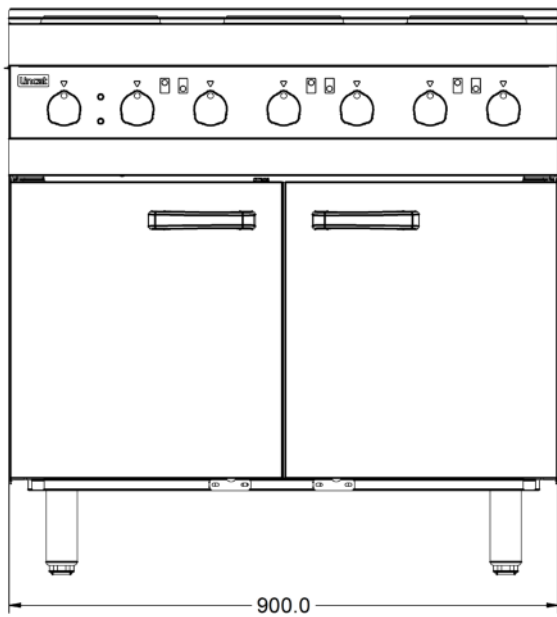
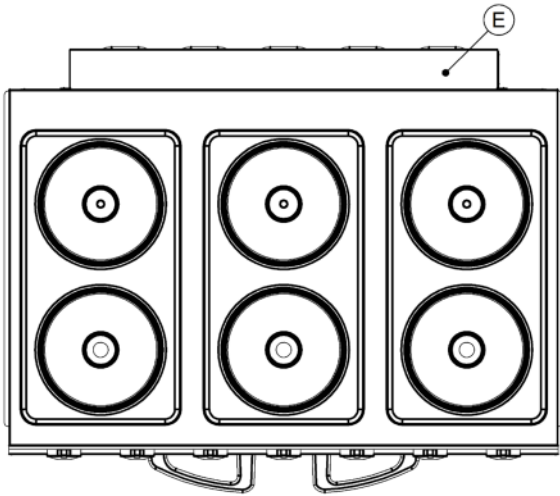

Lincat Limited

Whisby Road,
Lincoln, LN6 3QZ,
United Kingdom

Company No: 2175448

A member company of



Customer Care

Tel: +44 1522 875500
Email: care@lincat.co.uk

Export Customers

Tel: +44 1522 503250
Email: export@lincat.co.uk

Opening Hours

Monday – Friday:
8.30am – 5pm