



WATER



GAS



ENVIRONMENT



PEST CONTROL

PRODUCT DATA SHEET: BIOLOGICAL DRAIN MAINTENANCE SYSTEMS

GREASEPAK

Biological Drain Maintenance System

A unique, automatic drain dosing system specifically designed to address the drainage problems found in commercial kitchens. Preventing the build-up of Fats, Oils and Grease [FOGs] leaving staff free to run the kitchen.



DEGRADE FOGs IN COMMERCIAL KITCHEN DRAINS

EASY TO USE...



The GreasePak unit delivers a daily dose of bio-fluid into the drain.

The specially formulated bio-fluid degrades fats, oils & grease (FOGs).

Grease build up is prevented and your drains stay clear and odour-free.

THE BENEFITS...

GreasePak can be installed almost anywhere in the kitchen

GreasePak™ is a stylish, discreet and easy-to-clean, self-contained wall-mounted dosing unit that takes up no floor space and is very simple to install and operate.

- Simple design, few working parts – trouble free!
- Bio-fluid refills are easy to store, handle and change
- Choice of long-life, battery operated unit or mains-powered
- A cost effective and efficient solution

Helps to keep drains clear of fats, oils and grease (FOGs)

Designed to address the drainage problems found in commercial kitchens. The GreasePak unit doses the drain with a blend of specially selected microorganisms that have been chosen for their ability to degrade fats, oils and grease (FOGs) in low oxygen conditions (such as closed drains) and where pH levels fluctuate.

- Eco-friendly, uses no harsh chemicals
- Can work on its own or in conjunction with a grease trap
- Helps to prevent drains from smelling

An effective, environmentally friendly commercial solution

GreasePak bio-fluid is an environmentally friendly Class 1 biodegradable product that degrades FOGs into smaller, simpler molecules that cannot reform or solidify. These degraded products are then further digested by the bacterial population or are quickly washed away.

- Helps satisfy legislation and building regulations by providing an effective means of grease removal
- Only bioremediation system to be BBA-approved





MODEL: **GP-DMI-MAINS-2**



MAINS-powered (battery operated model also available)

Model: GP-DMI-MAINS-2 - Mechline's GreasePak, mains-powered, biological drain maintenance system.

Manufacturer: Mechline Developments Limited

PURPOSE

Mechline's GreasePak is a unique, safe, automatic drain dosing system specifically designed to prevent the recurrence of drain blockages from Fats, Oils, Grease (FOGs) and starches in commercial kitchens. Use in conjunction with a grease trap or as a stand alone drain maintenance system. GreasePak's highly developed and powerful bio-fluid solution deals with FOGs helping to maintain free-running drains, decrease odours and avoid blockages. Helps foodservice operators meet with legislative demands to have an effective means of grease removal.

FEATURES & BENEFITS

- Compact automatic dosing system
- Mains-powered (battery operated model also available)
- Easy to install and operate – No water connection required
- Affordable, easy to manage and easy to clean with built-in buzzer to remind you to replace fluid
- Meets Building Regulations for an effective means of grease removal
- Most powerful, multi-strain, bio-fluid of its type – degrades FOGs into simple molecules that cannot reform or solidify
- Bio-fluid is 100% natural and safe
- Use alone or with grease traps
- Reduce the need for grease trap cleaning by over 50% – saving money!
- Less chance of foul odours and less chance of attracting vermin and pests
- Environmentally responsible

ACCREDITATIONS

- CE-certified
- BBA-approved, certificate 11/4827
- Manufactured to ISO 9001-2008 standards

MATERIAL / COLOUR / DESCRIPTION

Compact white ABS plastic dosing module with audible alarm.

WEIGHT

- 3.4 Kg (without fluid box fitted)
- 8.9 Kg (with fluid box fitted)

SPECIAL NOTES

GreasePak is a drain maintenance system, not a drain unblocking system.

IMPORTANT: Existing drains must be cleaned and pressure washed prior to installation. Failure to do this could result in dislodged fat and grease blocking the drains further downstream.

It may be necessary to install more than one GreasePak system in a kitchen if multiple grease risk areas are identified.

Care & maintenance: GreasePak is designed to be easy to clean. Never use abrasives or harsh cleaning chemicals and bleach.

IMPORTANT: To ensure best performance from GreasePak, DO NOT introduce bleach or other harsh chemicals into the drainage system as the effectiveness of the GreasePak fluid will be compromised. Avoid using cleaning products containing biocide, limonene and terpenes.

SITE REQUIREMENTS

There is no need to prepare a site for installation of a GreasePak unit. It can be situated where needed as long as the installation advice in the Operator Manual is followed. The location of the GreasePak system is important for optimum performance and drains must be cleaned and pressure washed prior to installation.

Operational notes:

- Electrical supply: 230 V, 50 Hz, 1 phase, 3 amp fuse
- Hardwiring required to switched spur outlet (3 metre cable supplied)
- Unit is totally insulated
- Internal transformer is 1.6VA to 6v
- Solenoid maximum draw is 266mA @ 6v. Switching duration is 2.5ms
- Primary side current demand for duration of solenoid operation 0.0069 A (6.9mA) @ 230v
- Replacement of bio-fluid (1x 5-Litre box approximately every month)

ON-GOING MACHINE REQUIREMENTS

- **GP-MSGD5** - Bio-Fluid Pack Master Box. A highly specialised biological preparation for breaking down fats, oils and grease (FOGs) in commercial kitchen drains. Supplied in master boxes of 3x 5-Litre. A master box should last 3 months under normal dosing conditions. (Shelf life 18 months).

WARRANTY

One-year manufacturer's warranty from the date of invoice, against defective parts or faulty workmanship. Terms and conditions apply. (Bio-fluid is a 'consumable' good and not subject to warranty).

RECOMMENDED USE

Ideal for sites wanting to prevent the recurrence of drain blockages from fats, oils and grease (FOGs) including starches, and to help meet legislative demands.

SIMILAR PRODUCTS

Model: GP-DMI-STD-2 - battery operated model

TECHNICAL ASSISTANCE: Call 0044 (0)1908 261511 and ask for the Technical Helpdesk or e-mail service@mechline.com

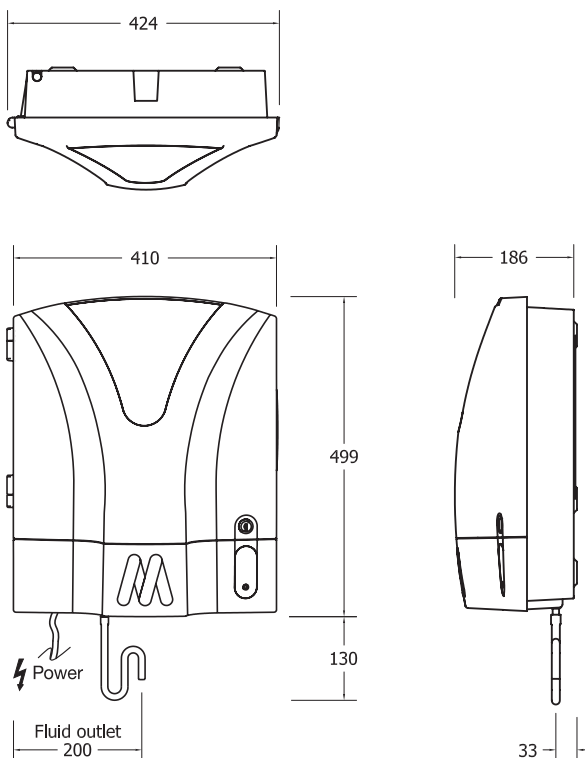

Note: If a CAD file is required please contact our Technical Helpdesk.

