

PLAN VIEW

GANTRY MOUNTED DIGITAL CONTROL PANEL

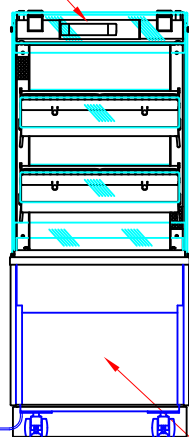

FRONT VIEW (CUSTOMER SIDE)

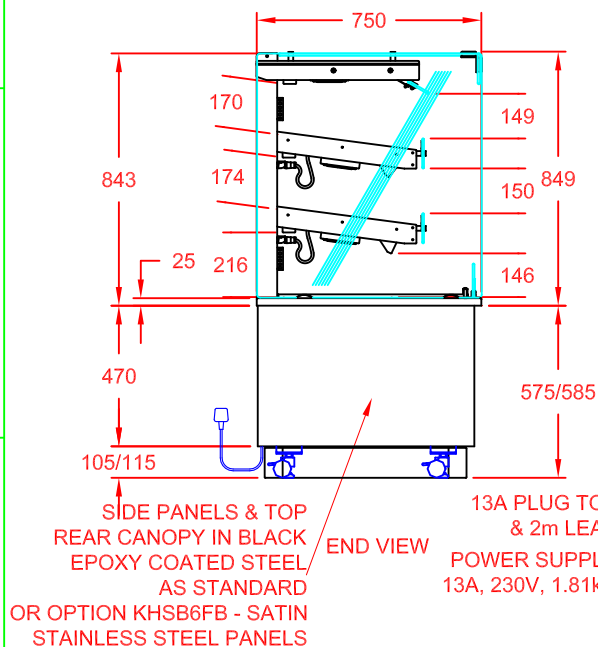
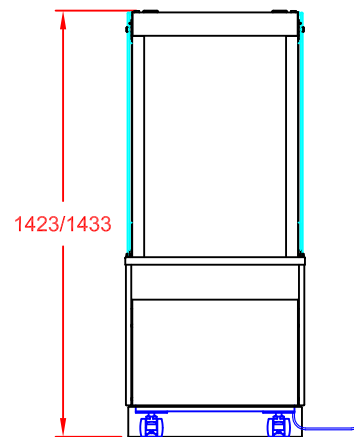

REAR VIEW (OPERATOR SIDE)

OPTIONAL FRONT FASCIA PANELS  
 KABF6 - BLACK EPOXY COATED STEEL  
 KASF6 - SATIN STAINLESS STEEL  
 FOR FREE STANDING MODELS

1423/1433

APPROX. UN-CRATED WEIGHT OF UNIT: 120Kg



CED FABRICATIONS LTD  
 UNITS A1-A4, FALCON COURT  
 CLAYTON BUSINESS PARK  
 CLAYTON-LE-MOORS  
 HYNDBURN  
 LANCASHIRE BB5 5JD

This drawing and information herein is confidential to CED Fabrications Ltd. It is issued in confidence that it will not be disclosed to any third party in part or in whole without permission from CED FABRICATIONS Ltd.

© CED FABRICATIONS LTD

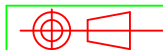

**DESCRIPTION:**

CABINET KUBUS PÂTISSERIE  
 600mm SELF HELP HEATED-FIXED BACK

SCALE: 1 : 2.5 @ A4

REV No: A

PRODUCT CODE:

KPH6FB