



MODEL MARK V

Full Size Electric Convection Oven



Project _____

Item No. _____

Quantity _____

Standard depth baking compartment - accepts five 18" x 26" standard full-size baking pans in left-to-right positions.

All data is shown per oven section, unless otherwise indicated.

EXTERIOR CONSTRUCTION

- Full angle-iron frame
- Stainless steel front, top and sides
- Dual pane thermal glass windows encased in stainless steel door frames
- Porcelain door handle with simultaneous door operation
- Triple-mounted pressure lock door design with turnbuckle assembly
- Modular slide out front control panel for easy access
- Solid mineral fiber insulation at top, back, sides and bottom

INTERIOR CONSTRUCTION

- Double-sided porcelainized baking compartment liner (14 gauge) for easy cleaning
- Aluminized blower wheel
- Five chrome-plated racks, eleven rack positions with a minimum of 1-5/8" (41mm) spacing
- Interior lights

OPERATION

- Three tubular heaters
- Solid state thermostat with temperature control range of 200°F (93°C) to 500°F (260°C)
- Two speed fan motor
- 1/3 horsepower blower motor with automatic thermal overload protection
- Control area cooling fan
- Four 50 watt commercial bake oven lamps

STANDARD FEATURES

- Solid state manual control with separate dials to control thermostat and timer
- Two year parts and labor oven warranty*
- Five year limited oven door warranty*

* For all international markets, contact your local distributor.



OPTIONS AND ACCESSORIES

(AT ADDITIONAL CHARGE)

- **Control options:**
 - Pulse Plus®
 - Cook & hold
 - Solid state digital control with LED display, cook and hold, and Pulse Plus®
 - Blodgett IQ®
- **Legs/casters:**
 - 6" (152mm) stainless steel legs
 - 6" (152mm) seismic legs
 - 6" (152mm) casters
 - 4-1/4" (108mm) low profile casters (double only)
 - 25" (635mm) stainless steel legs
- Open stand with rack guides, stainless steel
- Base cabinet
- Stainless steel oven liner
- Extra oven racks
- Solid stainless steel back
- 480 volt, 3 phase
- Prison package (includes security control panel and stainless steel back)
- Security control panel
- Vent connector

OPTIONS AND ACCESSORIES

(AT NO CHARGE)

- Solid stainless steel doors

BLODGETT OVEN COMPANY

www.maytagfoodservice.com

50 Lakeside Avenue, Burlington, VT 05402

Toll Free: (800) 331-5842 • Phone: (802) 860-3700 • Fax: (802) 864-0183

MODEL MARK V

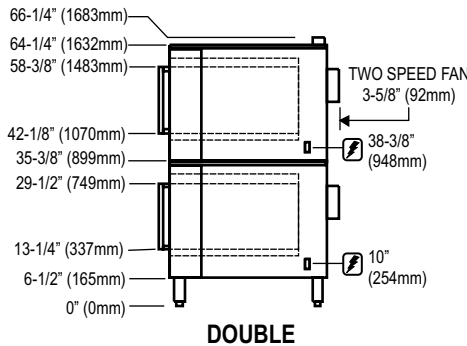
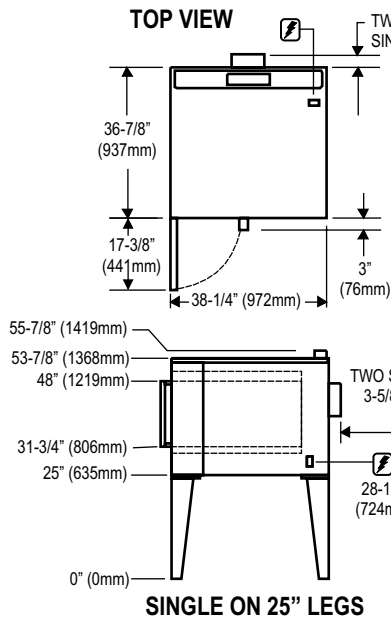
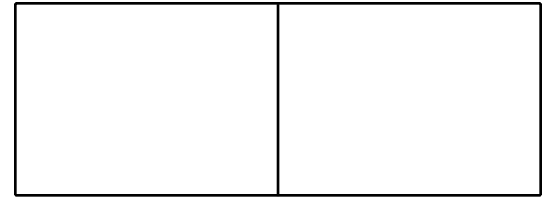

APPROVAL/STAMP

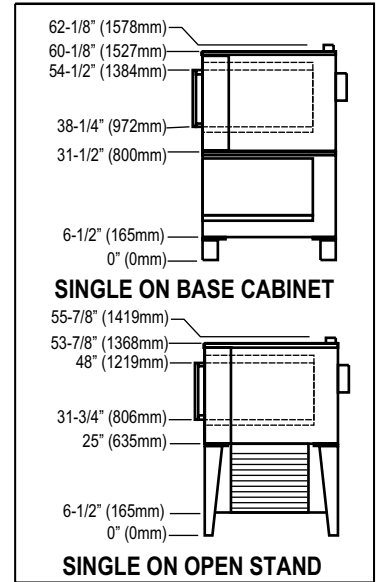

SHORT FORM SPECIFICATIONS

Provide Blodgett full-size convection oven model MARK V, (single/double) compartment. Each compartment shall have (porcelainized/stainless) steel liner and shall accept five 18" x 26" standard full-size bake pans. Doors shall (be solid stainless steel/ have dual pane thermal glass windows) with single porcelain handle and simultaneous operation. Unit shall be electrically heated with three tubular heaters. Air in baking chamber distributed by single inlet blower wheel powered by a two-speed, 1/3 HP motor with thermal overload protection. Each chamber shall be fitted with four commercial lamps and five chrome-plated removable racks. Control panel shall be recessed with Cook/Cool Down mode selector, solid state (manual/digital) thermostat (200 - 500° F), (93-260°C) and 60-minute timer. Provide options and accessories as indicated.

DIMENSIONS:

- Floor space** 38-1/4" (972mm) W x 36-7/8" (937mm) D
- Product clearance** 1/2" (12mm) from combustible and non-combustible construction
- Interior** 29" (737mm) W x 20" (508mm) H x 24-1/4" (616mm) D
- If oven is on casters add to all height dimensions:**
- Single 4" (114mm)
- Double 2" (57mm)

POWER SUPPLY:

V.A.C.	Hz	Phase	K.W.H.	Amperes (L1-L2-L3)
DOMESTIC				
208	60	1	11	51/0/51
208	60	3	11	31/29/29
220/240	60	1	11	44/0/44
220/240	60	3	11	26/24/24
440	60	3	11	15/14/14
480	60	3	11	14/13/13
1/3 H.P., 2 speed motor, 1140 and 1725 RPM (60Hz.)				

INTERNATIONAL

220/380	50	3	11	18/16/16
220/240	50	1	11	40/0/48
240/415	50	3	11	18/14/14
230/400	50	3	11	18/15/15

This oven contains a mercury relay. DO NOT put mercury relay in trash. Relay must be recycled or disposed of as hazardous waste.

MAXIMUM INPUT:

- Single 11KW
- Double 22KW (11KW each section)

MINIMUM ENTRY CLEARANCE:

- Uncrated 28-7/8" (733mm)
- Crated 34-1/16" (876mm)

SHIPPING INFORMATION:

- Approx. Weight:**
- Single 490 lbs. (227 kg)
- Double 980 lbs. (454 kg)

Crate sizes:

34-1/2" (876mm) x 49-1/2" (1257mm) x 34/2" (876mm)
(2 crates required for double)

NOTE: The company reserves the right to make substitutions of components without prior notice.

BLODGETT OVEN COMPANY

www.maytagfoodservice.com
50 Lakeside Avenue, Burlington, VT 05402
Toll Free: (800) 331-5842 • Phone: (802) 860-3700 • Fax: (802) 864-0183