



OE8113 - Opus 800  
Electric Free-standing  
Twin Tank Fryer - 2  
Baskets - W 600 mm -  
24.0 kW

An accurate Opus 800 Twin-Tank Free Standing Electric Fryer which comes with two independent fryer tanks for greater versatility.

- ✓ Two independently fryer tanks for greater versatility
- ✓ Accurate thermostatic control up to 190°C for consistent results and safe operation
- ✓ Hinged, lift out element, with safety interlock for easy tank access and cleaning

**Specifications**

**Summary**

<b>Range Name</b>	Opus 800
<b>Power Type</b>	Electric
<b>Unit Type</b>	Free-standing
<b>Available in UK Only</b>	No
<b>UK Warranty</b>	2 Years Parts and Labour Warranty
<b>Export Warranty</b>	Contact your local dealer
<b>GTIN Code</b>	5056105102960

**Power and Performance**

<b>Total Power kW</b>	24.0
<b>Temperature Range °C</b>	90 - 190
<b>IP Rating</b>	IP24
<b>Temperature Control</b>	Mechanical

**Key Specifications**

<b>Capacity Litres</b>	2 x 15.0
<b>Number of Baskets</b>	2
<b>Number of Tanks</b>	2
<b>Gravity Filtration</b>	No
<b>Pumped Filtration</b>	No
<b>Drain Location</b>	Through the body

**Weights and Dimensions**

<b>Unit Height (External) mm</b>	1020
<b>Unit Width (External) mm</b>	600
<b>Unit Depth (External) mm</b>	800
<b>Net Weight Kg</b>	99

**Supply Connections**

<b>Requires Installation</b>	Yes
<b>Requires Electrical Supply</b>	Yes
<b>UK 3 Pin Plug</b>	No
<b>Requires Hardwiring</b>	Yes
<b>Electrical Supply Rating Watts</b>	24,000
<b>Three Phase Amps</b>	L1=34.8 ; L2=34.8 ; L3=34.8
<b>Three Phase Voltage</b>	400

**Shipping**

<b>Packed Weight Kg</b>	111
<b>Packed Height cm</b>	122
<b>Packed Width cm</b>	70
<b>Packed Depth cm</b>	85

**Available Accessories**

<b>BA122</b>	1/2 BASKET FOR OPUS 800 - 300MM WIDE TANKS
<b>LK02</b>	OPUS 350 LEG KIT
<b>OA8954</b>	SPLASHGUARD FOR OPUS 800 ELECTRIC FRYERS
<b>OF2</b>	Oil filter kit - size 2

**Technical Picture**

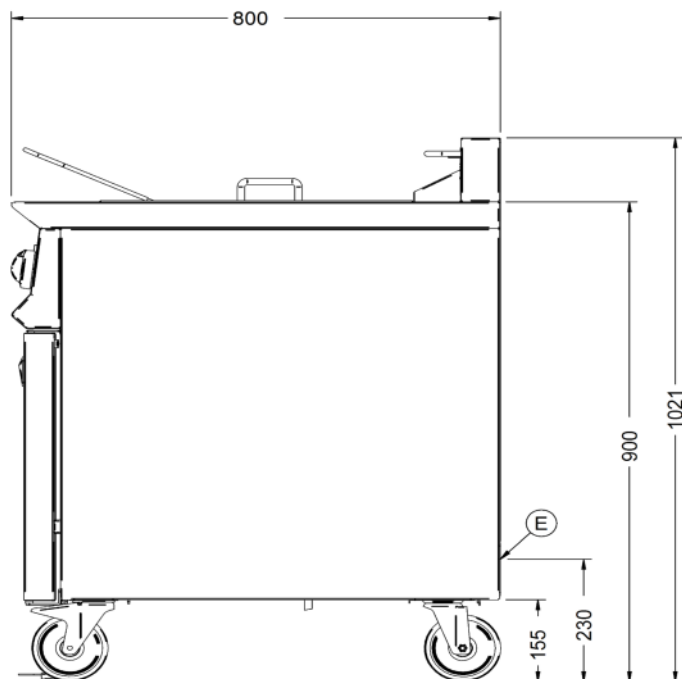
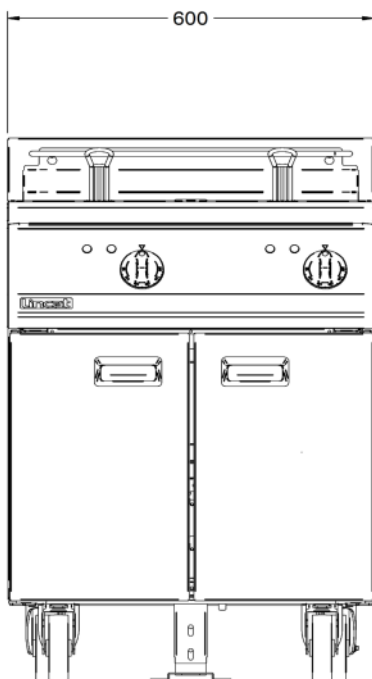
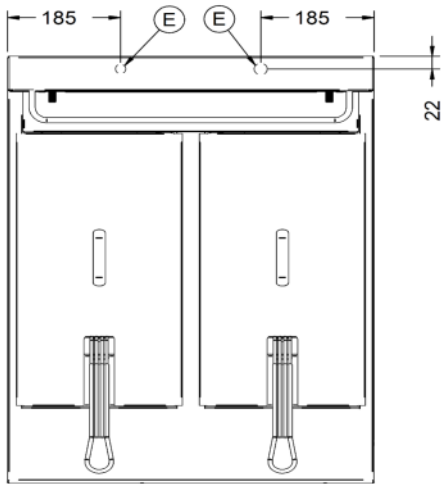

**Lincat Limited**

Whisby Road,  
Lincoln, LN6 3QZ,  
United Kingdom

**Company No:** 2175448

A member company of



**Customer Care**

**Tel:** +44 1522 875500  
**Email:** care@lincat.co.uk

**Export Customers**

**Tel:** +44 1522 503250  
**Email:** export@lincat.co.uk

**Opening Hours**

**Monday – Friday:**  
8.30am – 5pm