



OE8205/C - Opus 800
Electric Counter-top
Griddle - Chrome Plate -
W 600 mm - 8.0 kW

Designed for quality cooking at speed, the Opus 800 Electric Chrome Griddle heats up quicker than standard griddles with less energy loss as well as reduced energy radiation, keeping the kitchen cooler for staff and reducing pressure on the ventilation system.

- ✓ Chrome surface heats up quicker than standard griddles with less energy loss as well as reduced energy radiation, keeping the kitchen cooler for staff and reducing pressure on the ventilation system
- ✓ Transfers heat to food more efficiently than a standard griddle
- ✓ Two separately controlled heat zones give you the option of operating either zone independently to provide a smaller cooking area during quiet periods as well as offering versatility when cooking two separate meals simultaneously
- ✓ Precise thermostatic control up to 300°C for consistent results and economical operation

Specifications

Summary

Range Name	Opus 800
Power Type	Electric
Unit Type	Counter-top
Available in UK Only	No
UK Warranty	2 Years Parts and Labour Warranty
Export Warranty	Contact your local dealer
GTIN Code	5056105102519

Power and Performance

Total Power kW	8.0
Temperature Range °C	90 - 300
IP Rating	IP24
Cooking Area (Width x Depth) mm	590 x 600
Temperature Control	Mechanical

Key Specifications

Number of Heat Zones	2
Grill Plate Surface Type	Smooth
Grill Plate Material	Chrome

Weights and Dimensions

Unit Height (External) mm	428
Unit Width (External) mm	600
Unit Depth (External) mm	800
Net Weight Kg	81.5

Supply Connections

Requires Installation	Yes
Requires Electrical Supply	Yes
UK 3 Pin Plug	No
Requires Hardwiring	Yes
Electrical Supply Rating Watts	8,000
Single Phase Amps	34.8
Single Phase Voltage	230
Three Phase Amps	L1=17.4 ; L2=17.4 ; L3=N/A
Three Phase Voltage	400

Shipping

Packed Weight Kg	95
Packed Height cm	63
Packed Width cm	70
Packed Depth cm	85

Available Accessories

LK11	OPUS 800 LONG LEG KIT
OA8917	Opus 800 Free-standing Floor Stand with Legs - for units W 600 mm
OA8917/C	Opus 800 Free-standing Floor Stand with Castors - for units W 600 mm
OA8972	Opus 800 Free-standing Pedestal with Doors and Legs - for units W 600 mm
OA8972/C	Opus 800 Free-standing Pedestal with Doors and Castors - for units W 600 mm

Technical Picture

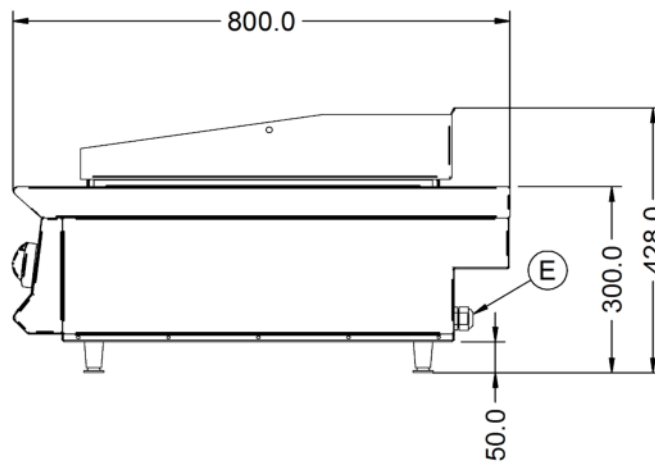
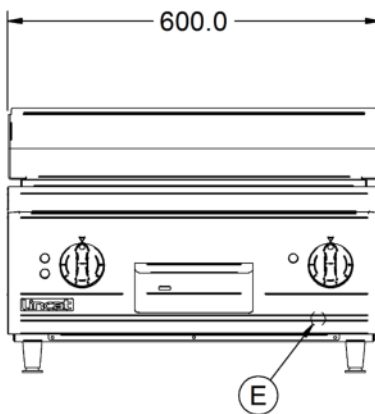
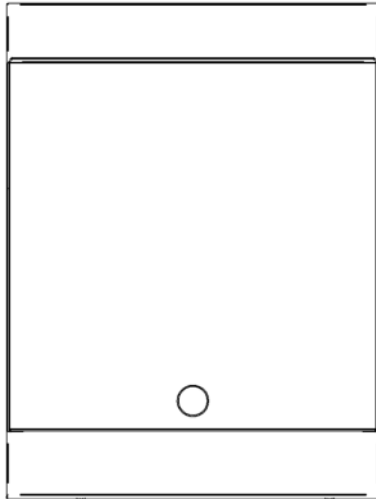

Lincat Limited

Whisby Road,
Lincoln, LN6 3QZ,
United Kingdom

Company No: 2175448

A member company of



Customer Care

Tel: +44 1522 875500
Email: care@lincat.co.uk

Export Customers

Tel: +44 1522 503250
Email: export@lincat.co.uk

Opening Hours

Monday – Friday:
8.30am – 5pm