



OE8205/R - Opus 800
Electric Counter-top
Griddle - Ribbed Plate - W
600 mm - 8.0 kW

With a half ribbed plate option for attractive branding presentation marks, the Opus 800 Electric Ribbed Plate Griddle is designed to create appetizing food accurately.

- ✓ Half ribbed plate option for attractive branding presentation marks
- ✓ Precise thermostatic control up to 300°C for consistent results and economical operation
- ✓ Maximised cooking area, griddle plates sit flush to the sides of the unit

Specifications

Summary **Power and Performance**

Range Name	Opus 800	Total Power kW	8.0
Power Type	Electric	Temperature Range °C	90 - 300
Unit Type	Counter-top	IP Rating	IP24
Available in UK Only	No	Cooking Area (Width x Depth) mm	590 x 600
UK Warranty	2 Years Parts and Labour Warranty	Temperature Control	Mechanical
Export Warranty	Contact your local dealer		
GTIN Code	5056105102526		

Key Specifications **Weights and Dimensions**

Number of Heat Zones	2	Unit Height (External) mm	428
Grill Plate Surface Type	Half-ribbed	Unit Width (External) mm	600
Grill Plate Material	Steel	Unit Depth (External) mm	800
		Net Weight Kg	76

Supply Connections **Shipping**

Requires Installation	Yes	Packed Weight Kg	91.5
Requires Electrical Supply	Yes	Packed Height cm	63
UK 3 Pin Plug	No	Packed Width cm	70
Requires Hardwiring	Yes	Packed Depth cm	85
Electrical Supply Rating Watts	8,000		
Single Phase Amps	34.8		
Single Phase Voltage	230		
Three Phase Amps	L1=17.4 ; L2=17.4 ; L3=N/A		
Three Phase Voltage	400		

Available Accessories

LK11	OPUS 800 LONG LEG KIT
OA8917	Opus 800 Free-standing Floor Stand with Legs - for units W 600 mm
OA8917/C	Opus 800 Free-standing Floor Stand with Castors - for units W 600 mm
OA8972	Opus 800 Free-standing Pedestal with Doors and Legs - for units W 600 mm
OA8972/C	Opus 800 Free-standing Pedestal with Doors and Castors - for units W 600 mm

Technical Picture

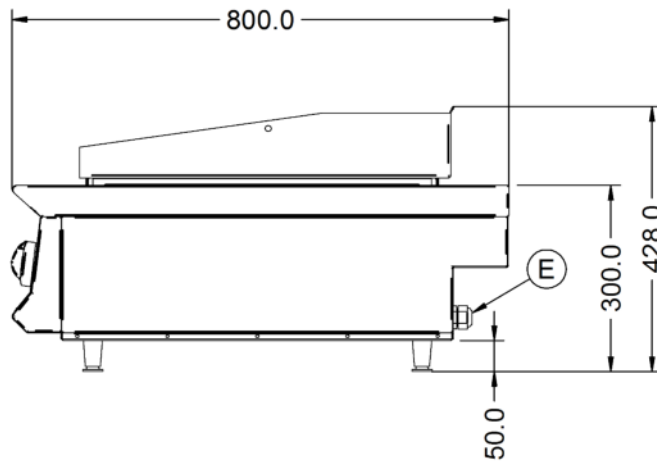
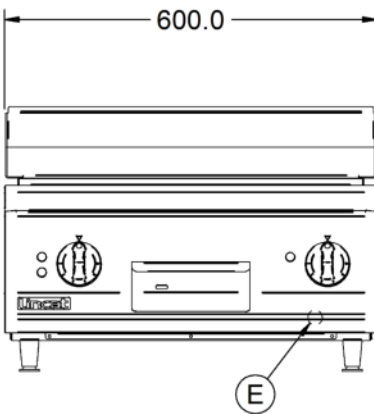
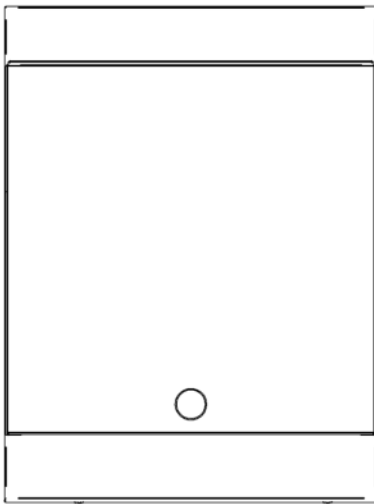

Lincat Limited

Whisby Road,
Lincoln, LN6 3QZ,
United Kingdom

Company No: 2175448

A member company of



Customer Care

Tel: +44 1522 875500
Email: care@lincat.co.uk

Export Customers

Tel: +44 1522 503250
Email: export@lincat.co.uk

Opening Hours

Monday – Friday:
8.30am – 5pm