

Combi oven

Convotherm mini
easyTouch mobil

- 6.06
- 6 shelves GN 2/3
- Electric
- Injection/Spritzer
- Right-hinged door



Key features

- Cooking methods: Steam, Combi-steam, Convection, Rethermalization
- Extra functions:
 - Crisp&Tasty – 3 moisture-removal settings
 - HumidityPro – 3 humidity settings
 - BakePro – 3 levels of traditional baking
 - Reduced fan speed and auto-reverse mode
- easyTouch 7" TFT HiRes glass touch display (capacitive)
- With built-in water and wastewater drawers (no fixed water supply connection required)
- Semi-automatic cleaning system
- HygieniCare
- WiFi and Ethernet interface (LAN)
- USB port integrated in the control panel
- TriColor indicator ring – indicates the current operating status
- Steam generated by injecting water into the cooking chamber
- Right-hinged appliance door with sure-shut function

Standard features

- Cooking methods:
 - Steam (30-130°C) with guaranteed steam saturation
 - Combi-steam (30-250 °C) with automatic moisture control
 - Convection (30-250 °C) with optimized heat transfer
 - Regenerating function
- Operation of easyTouch user interface:
 - 7" TFT HiRes glass touch display (capacitive)
 - Smooth-action, quick-reacting scrolling function
- Climate Management
 - HumidityPro
 - Crisp&Tasty
- Quality Management
 - Airflow Management
 - BakePro
 - Multi-point core temperature probe
 - Preheat and cool down function
- Cleaning Management
 - ConvoClean+ fully automatic cleaning system with 3 intensity levels, with a Clean and Care Booster
 - 10-minute Express cleaning
 - Safe Cool Down function before cleaning (when door is closed)
 - Cleaning profiles can be set individually as favourites
 - Cleaning calendar
- HygieniCare
 - Hygienic handles (door and hand-shower handles)
 - Hygienic Steam function
 - Hygienic touch film

Standard features

- Production Management
 - Automatic cooking with Press&Go with up to 399 profiles
 - Integrated cookbook with 7 different categories
 - TrayTimer – load management for different products at the same time (manual mode)
 - TrayView – Load management for automatic cooking of different products using Press&Go
 - Favorites management
 - HACCP data storage
 - WiFi and Ethernet interface (LAN)
 - ecoCooking – energy-save function
 - Low-temperature cooking / Delta-T cooking
 - Cook&Hold – cook and hold in one process
 - Auto Start
 - Add steam
 - Regenerate – flexible multi-mode rethermalization function with preselect
 - Flexible shelf spacing
 - Automatic moisture removal (for optional activation)*
 - Automatic cooling during cooking and baking (for optional activation)

* This means that the drinking water drawer must be refilled more frequently



Convotherm mini
easyTouch mobil

- 6.06
- 6 shelves GN 2/3
- Electric
- Injection/Spritzer
- Right-hinged door



Key features

- Cooking methods: Steam, Combi-steam, Convection, Rethermalization
- Extra functions:
 - Crisp&Tasty – 3 moisture-removal settings
 - HumidityPro – 3 humidity settings
 - BakePro – 3 levels of traditional baking
 - Reduced fan speed and auto-reverse mode
- easyTouch 7" TFT HiRes glass touch display (capacitive)
- With built-in water and wastewater drawers (no fixed water supply connection required)
- Semi-automatic cleaning system
- HygieniCare
- WiFi and Ethernet interface (LAN)
- USB port integrated in the control panel
- TriColor indicator ring – indicates the current operating status
- Steam generated by injecting water into the cooking chamber
- Right-hinged appliance door with sure-shut function

Options

- Left-hinged appliance door
- Available in various voltages
- Safety door latch (with sure-shut function and venting position)

Accessories

- KitchenConnect®
- Stands in various sizes and designs
- Care products for ConvoClean cleaning system
- Wall holder

Front view

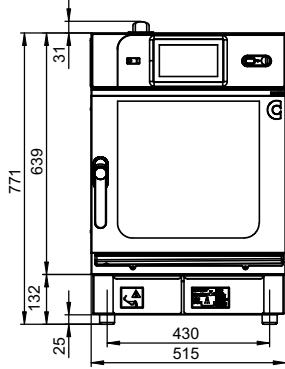

Side view

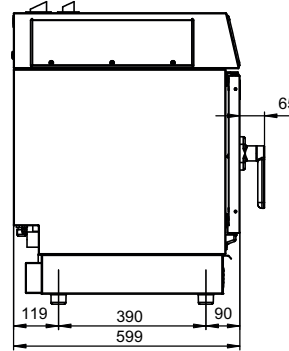

View from above with wall clearances

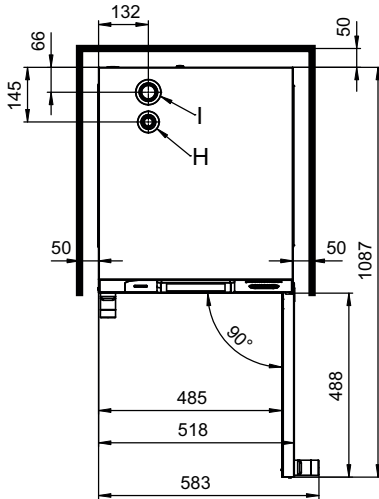

Connection points

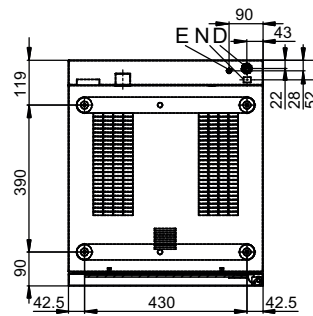

- A Drinking water drawer
- B Wastewater drawer
- D Electrical connection
- E Equipotential bonding
- H Air vent \varnothing 30mm
- I Dry air intake \varnothing 43mm
- N RJ45 Ethernet port
- Q Safety thermostat reset

Rear view

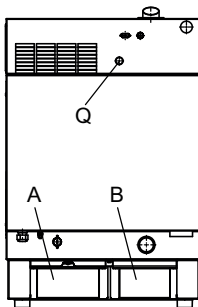

Dimensions and weights

Dimensions including packaging	
Width x Height x Depth	580 x 955 x 740 mm
Weight	
Empty weight without packaging	54 kg
Weight of packaging	12 kg
Safety clearances*	
Rear	50 mm
Right	50 mm
Left (larger gap recommended for servicing)	50 mm
Top**	500 mm

* Minimum distance from heat sources: 500 mm.

** Depends on type of air ventilation system and nature of ceiling.

Loading capacity

Max. number of food containers	
GN 2/3 depth 40 mm	6
GN 2/3 depth 65 mm	4
Plates max. Ø 28 cm,	4
Maximum loading weight	
GN 2/3, per combi oven	13 kg
GN 2/3, per shelf level	5 kg

Electrical supply

3N~ 400V 50/60Hz (3/N/PE)	
Rated power consumption	5.7 kW
Convection power	5.4 kW @ 230V
Motor power	0.25 kW
Rated current	11.8 A
Fuse rating	16A
Recommended conductor cross-section	5G2.5
1N~ 230V 50/60Hz (1/N/PE)	
Rated power consumption	3.0 kW
Convection power	2.7 kW @ 230V
Motor power	0.25 kW
Rated current	13.1 A
Fuse rating	16 A
Recommended conductor cross-section	3G2.5

Water connection

Water drawer capacity	
Drinking water drawer	5.5 l
Wastewater drawer	4.5 l

Water quality

General requirements	Drinking water, typically soft water (install water treatment system if necessary)
General hardness	4 - 7 °dh / 70 - 125 ppm / 7 - 13 °TH / 5 - 9 °e
pH value	6.5 - 8.5
Cl ⁻ (chloride)	max. 60 mg/l
Cl ₂ (free chlorine)	max. 0.2 mg/l
SO ₄ ²⁻ (sulphate)	max. 150 mg/l
Fe (iron)	max. 0.1 mg/l
SiO ₂ (silicate)	max. 13 mg/l
NH ₂ Cl (monochloramine)	max. 0.2 mg/l
Temperature	max. 40 °C
Electrical conductivity	min. 20 µS/cm

Emissions

Dissipated heat*	
Latent heat	1000 kJ/h / 0.28 kW
Sensible heat	1100 kJ/h / 0.31 kW
Noise during operation	max. 60 dBA

* The dissipated heat values were measured as per DIN 18873-1 "Methods for measuring the energy use of equipment for commercial kitchens — Part 1". The type and frequency of appliance usage are decisive for the specification of an air conditioning and ventilation system. These values can be higher than the values indicated for dissipated heat. Guide values can be found in the technical literature, e.g. in VDI 2052. Please consult your specialized design engineer for planning an air conditioning and ventilation system.

ACCESSORIES

(Please refer to the Accessories brochure for detailed information)

Please observe the following points:

- This document is to be used solely for planning purposes.
- Please refer to the Installation manual for further technical data and guidance on installation and positioning.