



## P8P6 - Lincat Panther 800 Series Free-standing Hot Cupboard - Plain Top - W 2180 mm - 2.5 kW

Helping to cater in demanding environments such as cafeterias, canteens and restaurants, the Panther 800 Series Hot Cupboard is perfect for plating and garnishing and as a pass to front of house staff, while it also provides extra workspace or can be used as a mobile workstation.

- ✓ Helping to cater in demanding environments such as cafeterias, canteens and restaurants
- ✓ Fan assisted hot cupboard provides even heat distribution, fast heat up and recovery times, and lower energy usage. Four shelf positions allow adjustment to meet individual needs.
- ✓ Fully 1/1 GN compatible hot cupboard for operational efficiency. Units available to take 6 x 1/1 GN containers up to 150mm deep.
- ✓ Accurate digital electronic control of the hot cupboard temperature, adjustable between 20 and 99 °C, ensures compliance with food hygiene regulations
- ✓ Double skinned construction provides efficient heat retention and a cool to touch exterior - safe and energy efficient. Removable doors and shelves allow access to the fully stainless steel interior for easy cleaning
- ✓ Supplied with two heavy duty multi-section chrome plated rod shelves capable of taking the heaviest loads

### Specifications

#### Summary

|                             |                                   |
|-----------------------------|-----------------------------------|
| <b>Brand</b>                | Lincat                            |
| <b>Range</b>                | Panther                           |
| <b>Series</b>               | 800 Series                        |
| <b>Power Type</b>           | Electric                          |
| <b>Unit Type</b>            | Free-standing                     |
| <b>Available in UK Only</b> | No                                |
| <b>UK Warranty</b>          | 2 Years Parts and Labour Warranty |
| <b>Export Warranty</b>      | Contact your local dealer         |
| <b>GTIN</b>                 | 5056105103615                     |

#### Power and Performance

|                             |            |
|-----------------------------|------------|
| <b>Total Power kW</b>       | 2.50       |
| <b>Temperature Range °C</b> | 20-99      |
| <b>IP Rating</b>            | IP24       |
| <b>Temperature Control</b>  | Electronic |

#### Key Specifications

|                                   |        |
|-----------------------------------|--------|
| <b>Number of Shelves included</b> | 2      |
| <b>Number of Shelf Positions</b>  | 4      |
| <b>Heated Base</b>                | Yes    |
| <b>Heated Gantry</b>              | No     |
| <b>Static or Mobile</b>           | Mobile |

#### Capacity

|                       |     |
|-----------------------|-----|
| <b>Plate Capacity</b> | 556 |
|-----------------------|-----|

#### Weights and Dimensions

|                                  |       |
|----------------------------------|-------|
| <b>Unit Height (External) mm</b> | 900   |
| <b>Unit Width (External) mm</b>  | 2180  |
| <b>Unit Depth (External) mm</b>  | 850   |
| <b>Height (Internal) mm</b>      | 432   |
| <b>Width (Internal) mm</b>       | 1,995 |
| <b>Depth (Internal) mm</b>       | 512   |
| <b>Shelf Dimensions Width mm</b> | 1,929 |
| <b>Shelf Dimensions Depth mm</b> | 512   |
| <b>Net Weight Kg</b>             | 197   |

#### Supply Connections

|                                       |       |
|---------------------------------------|-------|
| <b>Requires Installation</b>          | No    |
| <b>Requires Electrical Supply</b>     | Yes   |
| <b>UK 3 Pin Plug</b>                  | Yes   |
| <b>Requires Hardwiring</b>            | No    |
| <b>Electrical Supply Rating Watts</b> | 2,500 |
| <b>Single Phase Amps</b>              | 10.9  |
| <b>Single Phase Voltage</b>           | 230   |

### Shipping

|                         |     |
|-------------------------|-----|
| <b>Packed Weight Kg</b> | 213 |
| <b>Packed Height cm</b> | 110 |
| <b>Packed Width cm</b>  | 222 |
| <b>Packed Depth cm</b>  | 90  |

### Available Options

#### Overshelf or Gantry

|              |                               |
|--------------|-------------------------------|
| <b>PS6A1</b> | PS6A1 - 1 Ambient Overshelf   |
| <b>PS6A2</b> | PS6A2 - 2 Ambient Overshelves |
| <b>PS6A3</b> | PS6A3 - 3 Ambient Overshelves |
| <b>PS6H1</b> | PS6H1 - 1 Heated Overshelf    |
| <b>PS6H2</b> | PS6H2 - 2 Heated Overshelves  |
| <b>PS6H3</b> | PS6H3 - 3 Heated Overshelves  |

#### Door Locks

|             |                      |
|-------------|----------------------|
| <b>PDL6</b> | PDL6 - Lockable Door |
|-------------|----------------------|

#### Corner Guards

|            |                                  |
|------------|----------------------------------|
| <b>PCG</b> | PCG - Corner Guards[Set of Four] |
|------------|----------------------------------|

#### Trayslides

|             |                   |
|-------------|-------------------|
| <b>PTS6</b> | PTS6 - Tray Slide |
|-------------|-------------------|

#### Legs/Castors

|            |                            |
|------------|----------------------------|
| <b>PLK</b> | PLK - Legs[non chargeable] |
|------------|----------------------------|

### Available Accessories

|              |   |
|--------------|---|
| <b>PLK/S</b> | PLK/S - LEG KIT [FOR CONVERSION IN THE FIELD] |
| <b>PPB8</b>  | PPB8 - ADDITIONAL PUSHBAR                     |

### Technical Picture

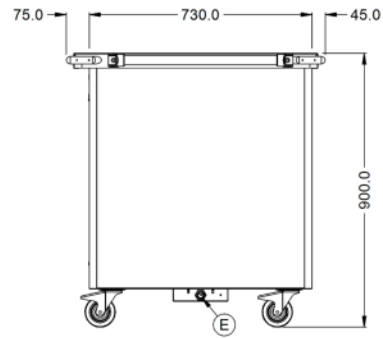
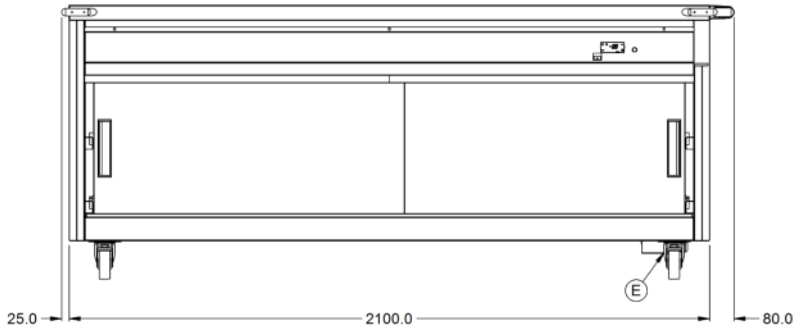

#### Lincat Limited

Whisby Road,  
Lincoln, LN6 3QZ,  
United Kingdom

**Company No:** 2175448

A member company of



#### Customer Care

**Tel:** +44 1522 875500  
**Email:** care@lincat.co.uk

#### Export Customers

**Tel:** +44 1522 875536  
**Email:** export@lincat.co.uk

#### Opening Hours

**Monday – Friday:**  
8.30am – 5pm