



SCH1085 - Seal Counter-top Heated Food Display Showcase - W 1085 mm - 2.05 kW

Showcase your delicious dishes with the gastronorm compatible Seal Heated Food Display.

- ✓ Attractive understated styling blends with any setting and enhances display for improved customer spend on food
- ✓ Fully-adjustable precise thermostatic control up to 95°C with digital display of cabinet
- ✓ Deep top shelf for increased display capacity - ideal for busy establishments
- ✓ Humidity feature prevents food drying out - food stays in optimum condition for longer, reducing waste
- ✓ Humidity feature prevents food drying out - food stays in optimum condition for longer, reducing waste

Specifications

Summary

Range Name	Seal
Power Type	Electric
Unit Type	Counter-top
Available in UK Only	No
UK Warranty	2 Years Parts and Labour Warranty
Export Warranty	Contact your local dealer
GTIN Code	5056105104391

Power and Performance

Gastronorm Capacity	3 x GN1/1
Total Power kW	2.05
Temperature Range °C	72 - 95
IP Rating	IP33
Temperature Control	Electronic

Key Specifications

Number of Shelves included	1
Number of Shelf Positions	1
Service Type	Back service
Rack Type	Static
Type of Lighting	Fluorescent
Heated Base	Yes

Weights and Dimensions

Unit Height (External) mm	665
Unit Width (External) mm	1085
Unit Depth (External) mm	750
Shelf Dimensions Width mm	1033
Shelf Dimensions Depth mm	355
Net Weight Kg	68

Supply Connections

Requires Installation	No
UK 3 Pin Plug	Yes
Requires Hardwiring	No
Electrical Supply Rating Watts	2,050
Single Phase Amps	8.9
Single Phase Voltage	230

Shipping

Packed Weight Kg	87.5
Packed Height cm	90
Packed Width cm	117
Packed Depth cm	85

Available Accessories

BP1085

BASEPLATE SCH1085

Technical Picture

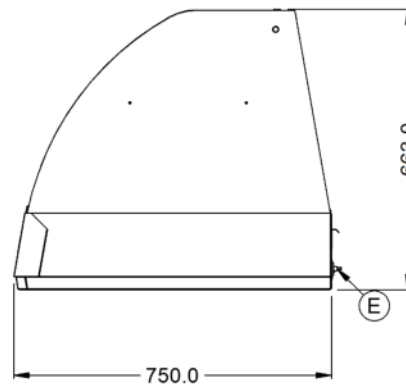
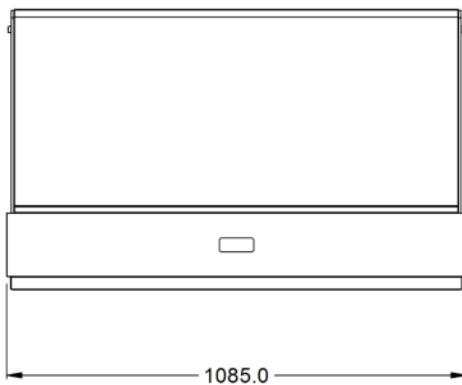

Lincat Limited

Whisby Road,
Lincoln, LN6 3QZ,
United Kingdom

Company No: 2175448

A member company of



Customer Care

Tel: +44 1522 875500
Email: care@lincat.co.uk

Export Customers

Tel: +44 1522 503250
Email: export@lincat.co.uk

Opening Hours

Monday – Friday:
8.30am – 5pm